

Minimize Pressure Drop While Filtering

107 W. Main Street  
Worthington PA 16262  
Phone: 724.297.3416  
Fax: 724.297.5189

# Mist Eliminator

ASME Code Vessels

Filtration Efficiency near 100%

Top Elliptical Head

External Industrial Paint

## INCREASED SAFETY

Air/Tak's design reduces overall weight and allows for higher standard pressure rating of 165 PSIG providing greater safety

## EFFICIENT FILTRATION

99.5% Liquid removal and 100% Particle removal with dual element design

## LOW PRESSURE DROP

Less than 1 PSID through 10 years average life vs 5-10 PSID of the conventional coalescer over one year.

## LONG TERM ELEMENT LIFE

Dual element design extends life 10 to 20 times saving changeouts

## EASY ELEMENT CHANGEOUT

Air/Tak's design utilizing the elliptical head greatly simplifies changing the element



## MIST ELIMATORS SPECIFICATIONS

MODEL	SCFM	VESSEL DIAMETER	IN/OUT CONN.	OVERALL HEIGHT (A)	OVERALL DIAMETER (B)	OUTLET TO FLOOR (C)
MESP-370	370 SCFM	16"	2"	57 9/16	23 1/2	55 1/16
MESP-550	550 SCFM	16"	2"	57 9/16	23 1/2	55 1/16
MESP-1100	1100 SCFM	16"	2.5"	73 5/16	23 1/2	53 1/2
MESP-1600	1600 SCFM	18"	3"	80 1/2	25	60
MESP-2000	2000 SCFM	20"	4"	85 7/16	27 1/2	63 7/8
MEDP-2600	2600 SCFM	20"	4"	85 1/2	27 1/2	63 15/16
MEDP-3400	3400 SCFM	24"	4"	83 15/16	32	59 1/8
MEDP-4400	4400 SCFM	24"	4"	95 7/16	32	70 5/8
MEDP-5200	5200 SCFM	24"	6"	107 13/16	32	82 7/8
MEDP-6200	6200 SCFM	24"	6"	121	32	96 1/2
MEDP-7800	7800 SCFM	30"	6"	111 3/4	38 3/4	84 15/16
MEDP-9300	9300 SCFM	30"	6"	123 3/4	38 3/4	96 15/16
MEDP-10100	10100 SCFM	30"	6"	129 3/4	38 3/4	102 15/16
MEDP-12400	12400 SCFM	36"	8"	129 11/16	46	99 3/8

**MESP** models include the single packed element.

**MEDP** models include the double packed element.

Maximum Working Pressure: 165 psig.

**OPTIONS AVAILABLE:** Stainless Steel Vessel  
Differential Pressure Gauge Kit  
Internal Epoxy

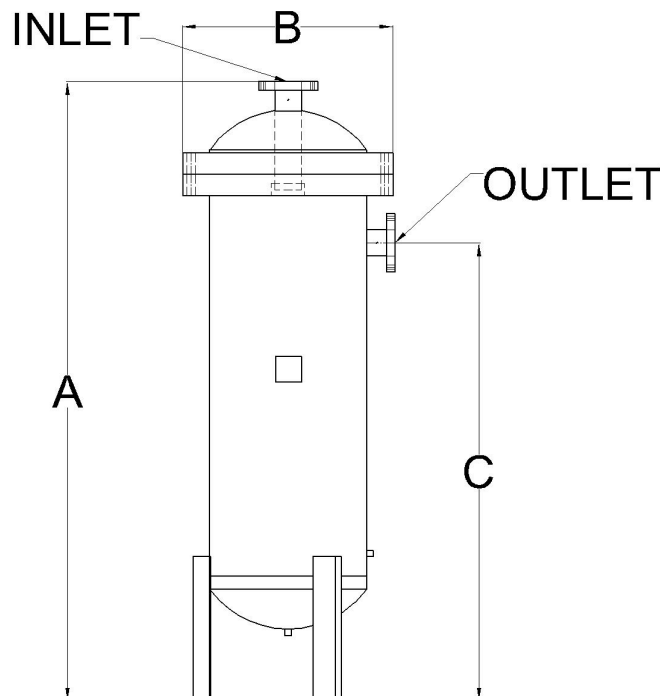

# AIR/TAK

**Compressed Air System Products**

107 West Main Street, Worthington, PA 16262 Phone: 724-297-3416 Fax: 724-297-5189

URL: <http://www.airtak.com> e-mail: [airtak@airtak.com](mailto:airtak@airtak.com)